

# Digital archives preservation:



a “culture broth” for  
a new archival paradigm



Alessandro Alfier  
Trieste, 19th October 2015

# Table of contents



**1)** "Polo archivistico dell'Emilia-Romagna" (ParER)

**2)** loyalty of ParER to the traditional archival paradigm

**3)** traces of a new archival paradigm in ParER

Inevitability of a shift of the archival paradigm in the digital context

# What is "Polo archivistico dell'Emilia-Romagna" (ParER)?

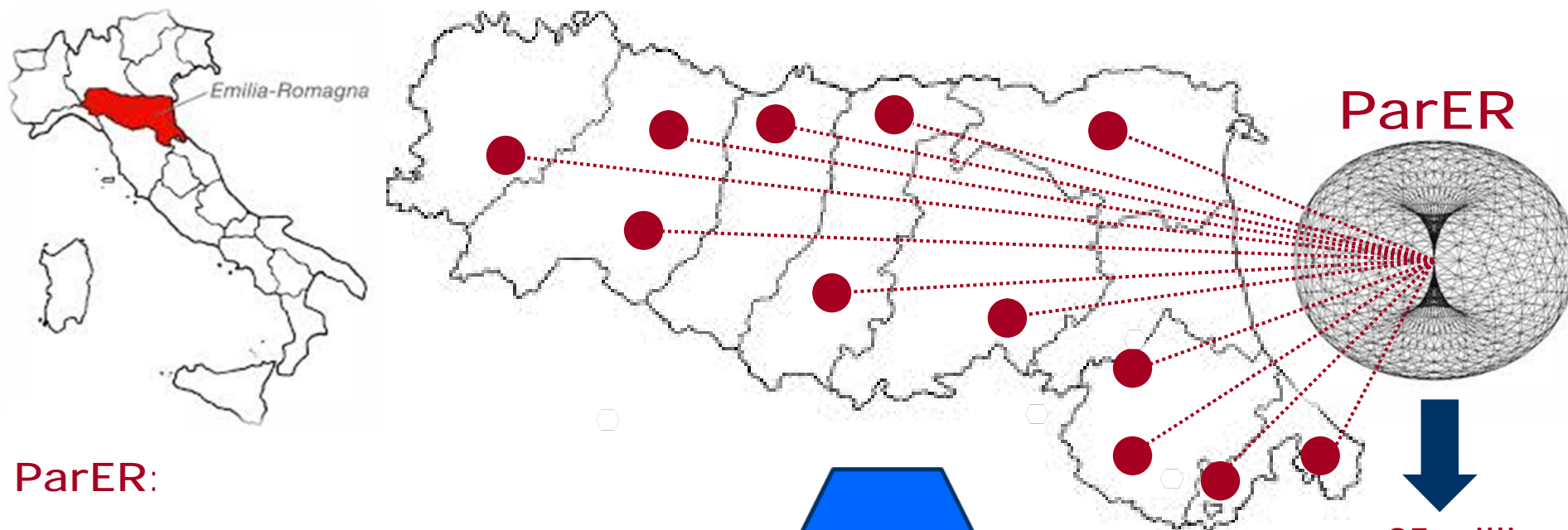

## ParER:

§ created by the Emilia-Romagna Regional Administration in 2008

§ for the purpose of long-term preservation of digital records

§ created by the different public administrations that work in this regional district

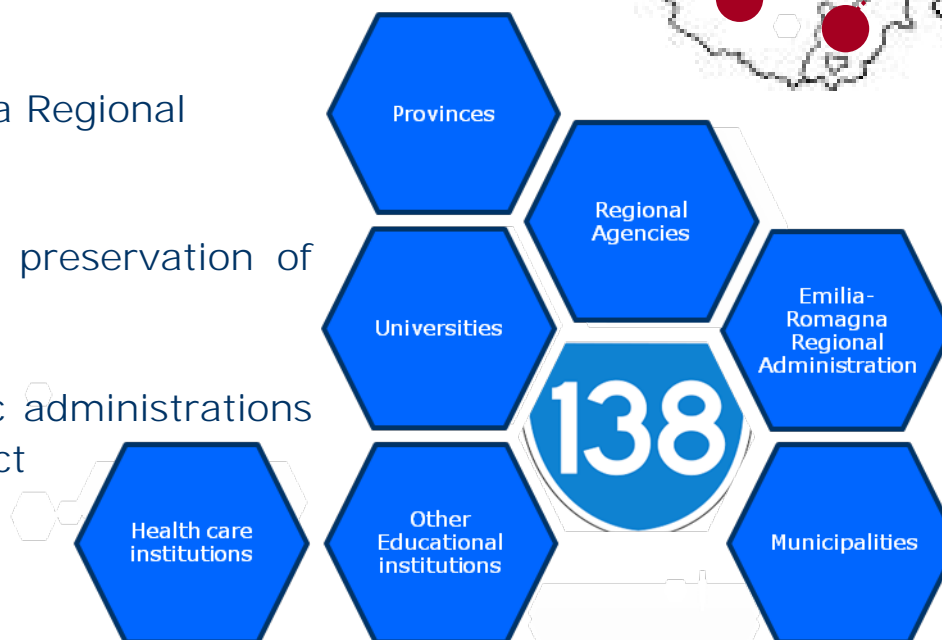

over **85 million**  
digital records  
preserved  
at the moment

# ParER and its multilayer functional structure

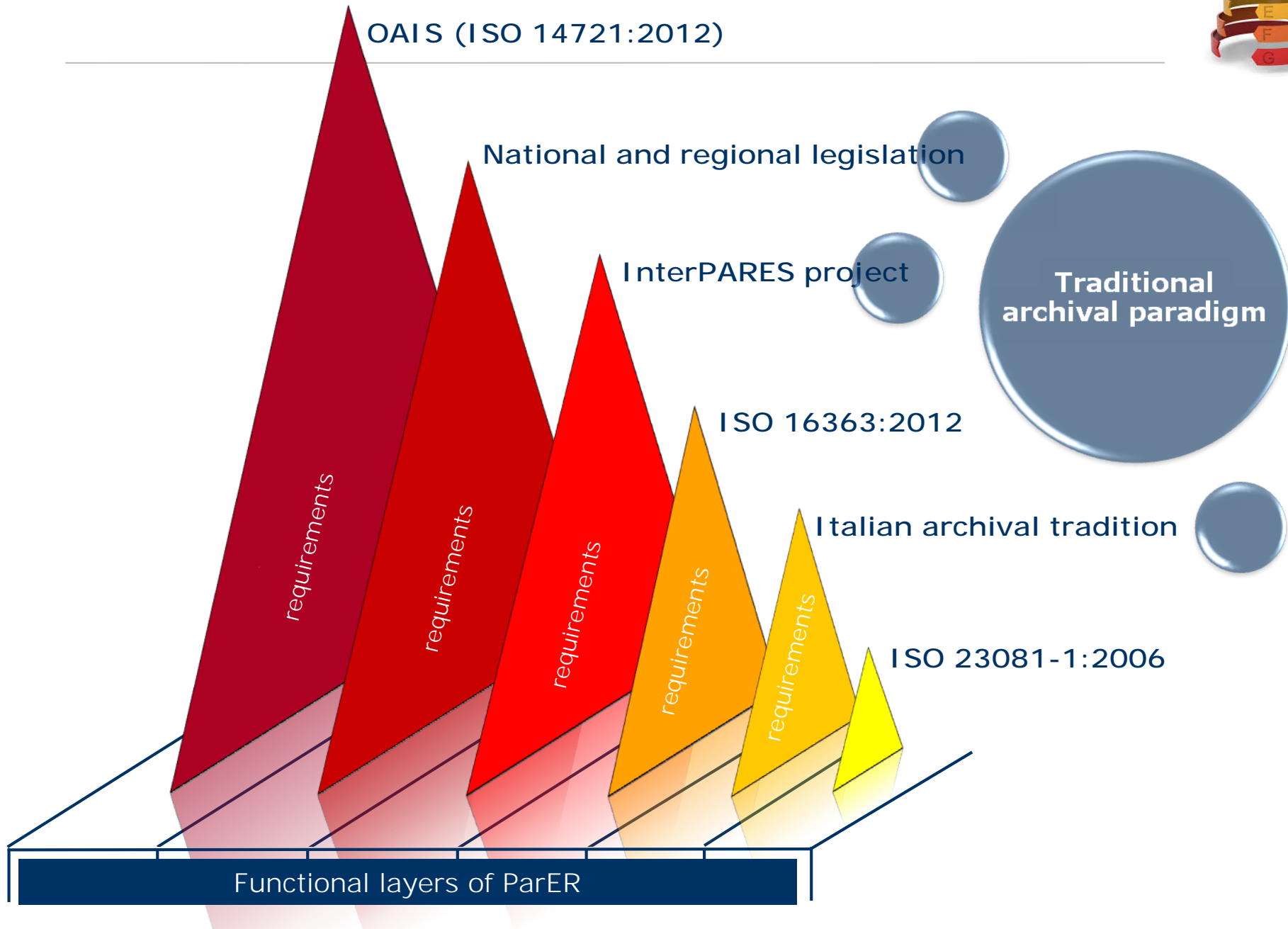

# The loyalty of ParER to the traditional archival paradigm

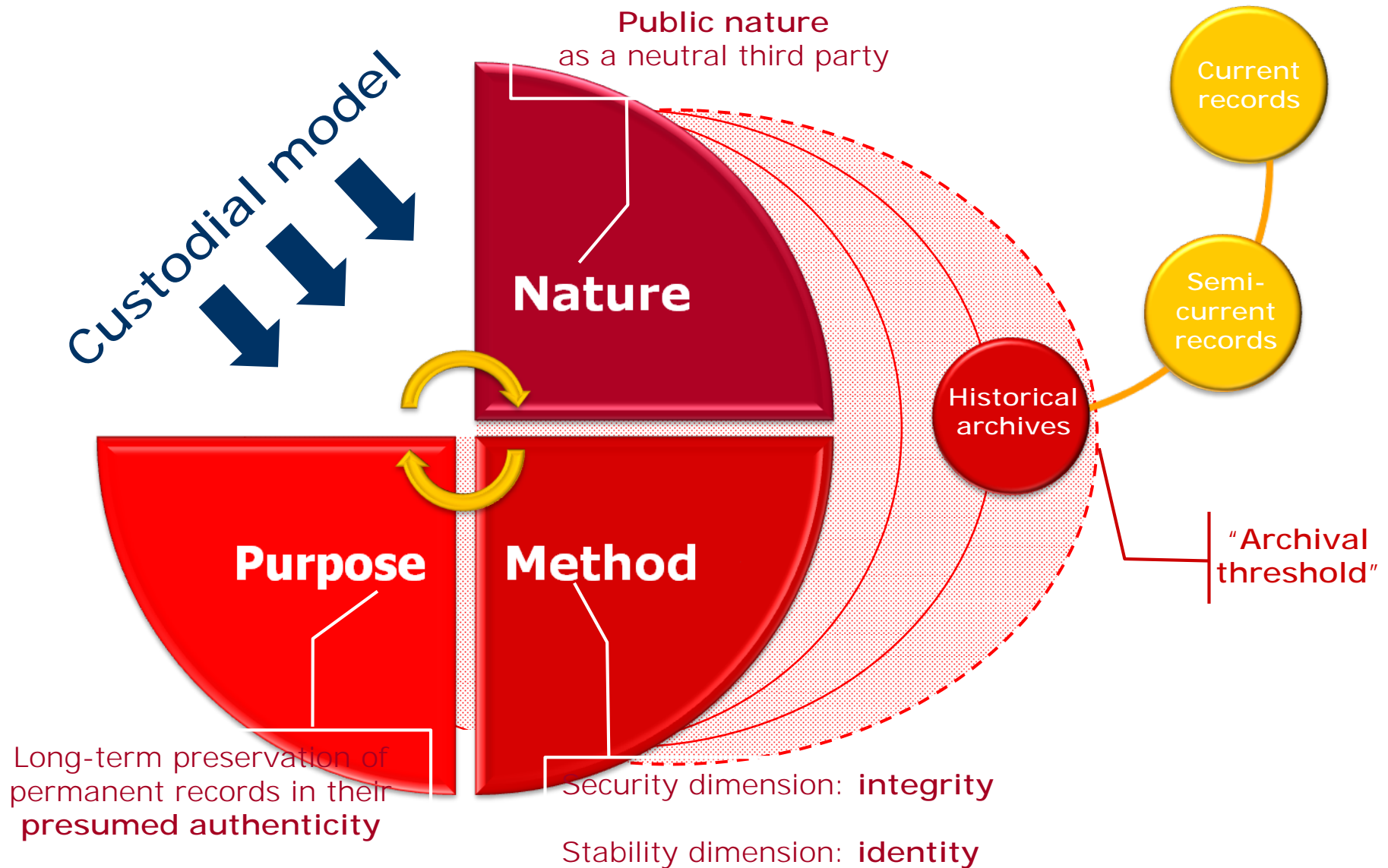

# The traces of a new archival paradigm in ParER

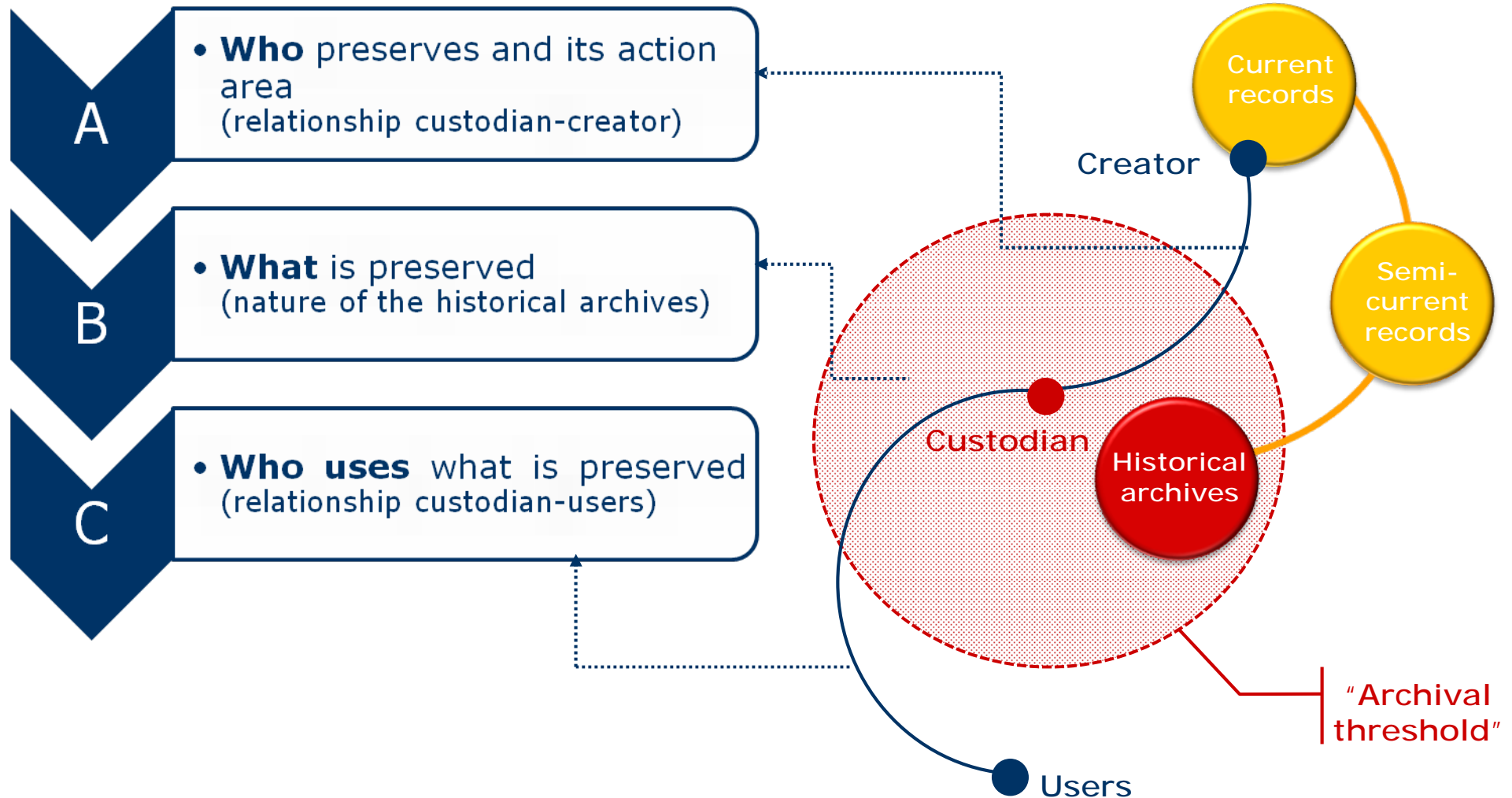

# The traces of a new archival paradigm (A): the relationship between ParER and the creator

To keep digital records means to adopt preventive measures:

**preservation**



**"Premature" transfer**

Digital records are entrusted to ParER when they are still active

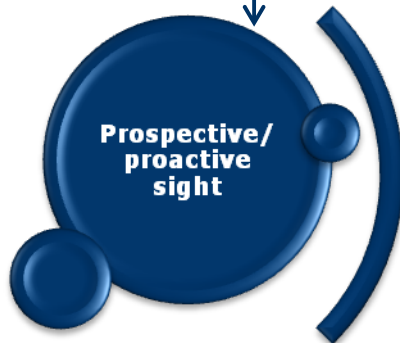
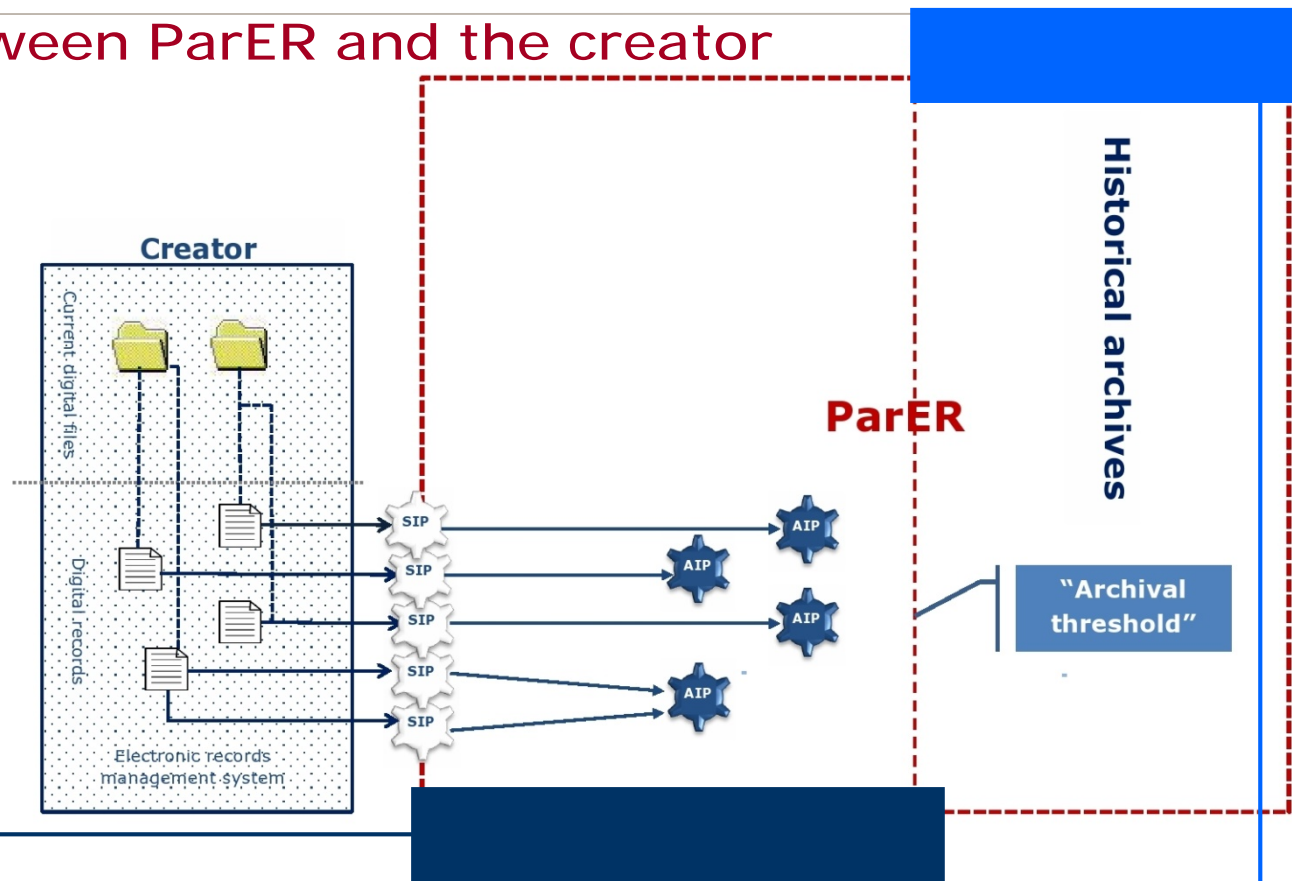

Shift in the traditional archival paradigm

Traditional archival paradigm

# The traces of a new archival paradigm (A): the relationship between ParER and the creator

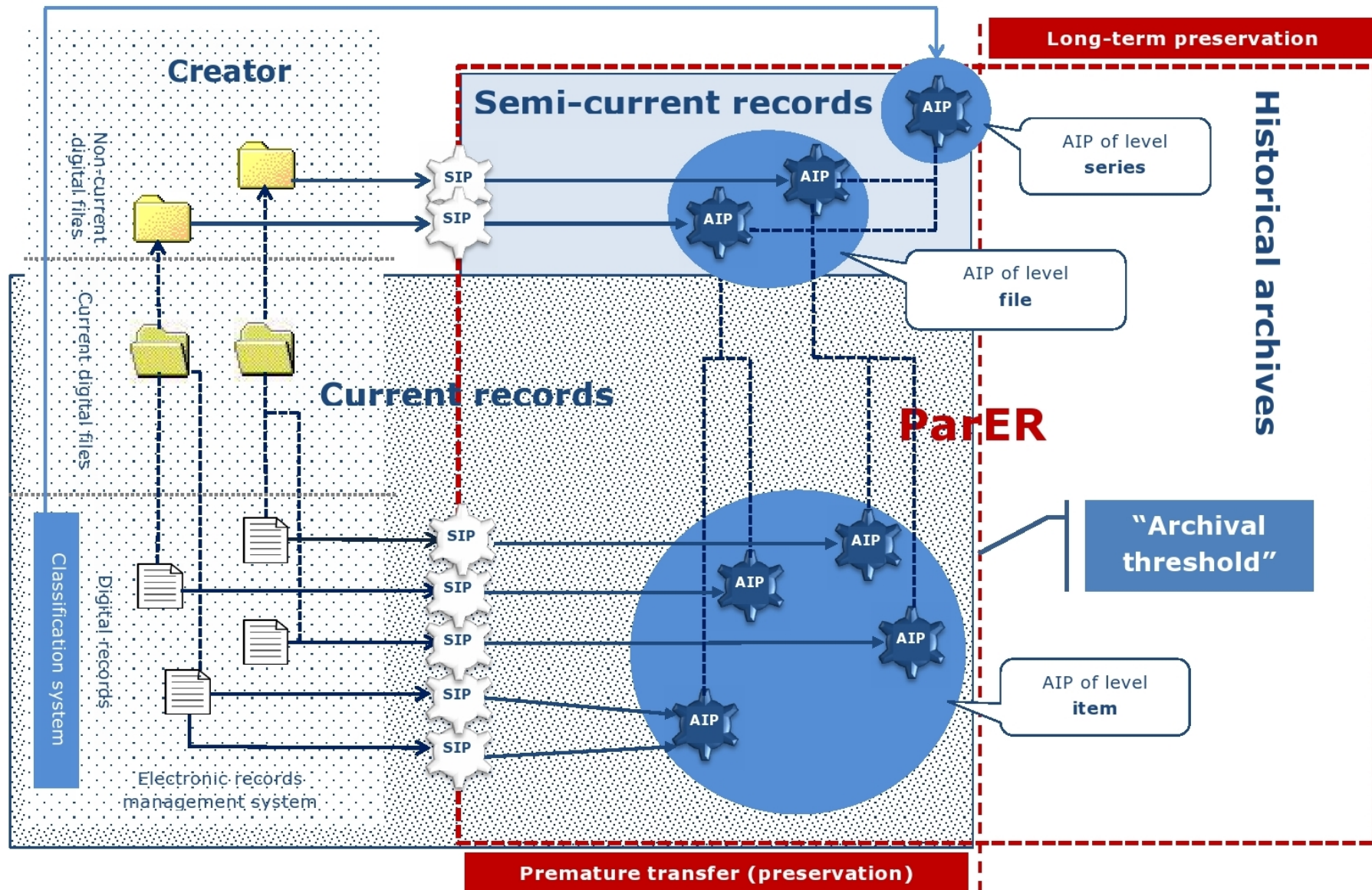



# The traces of a new archival paradigm (A): the relationship between ParER and the creator

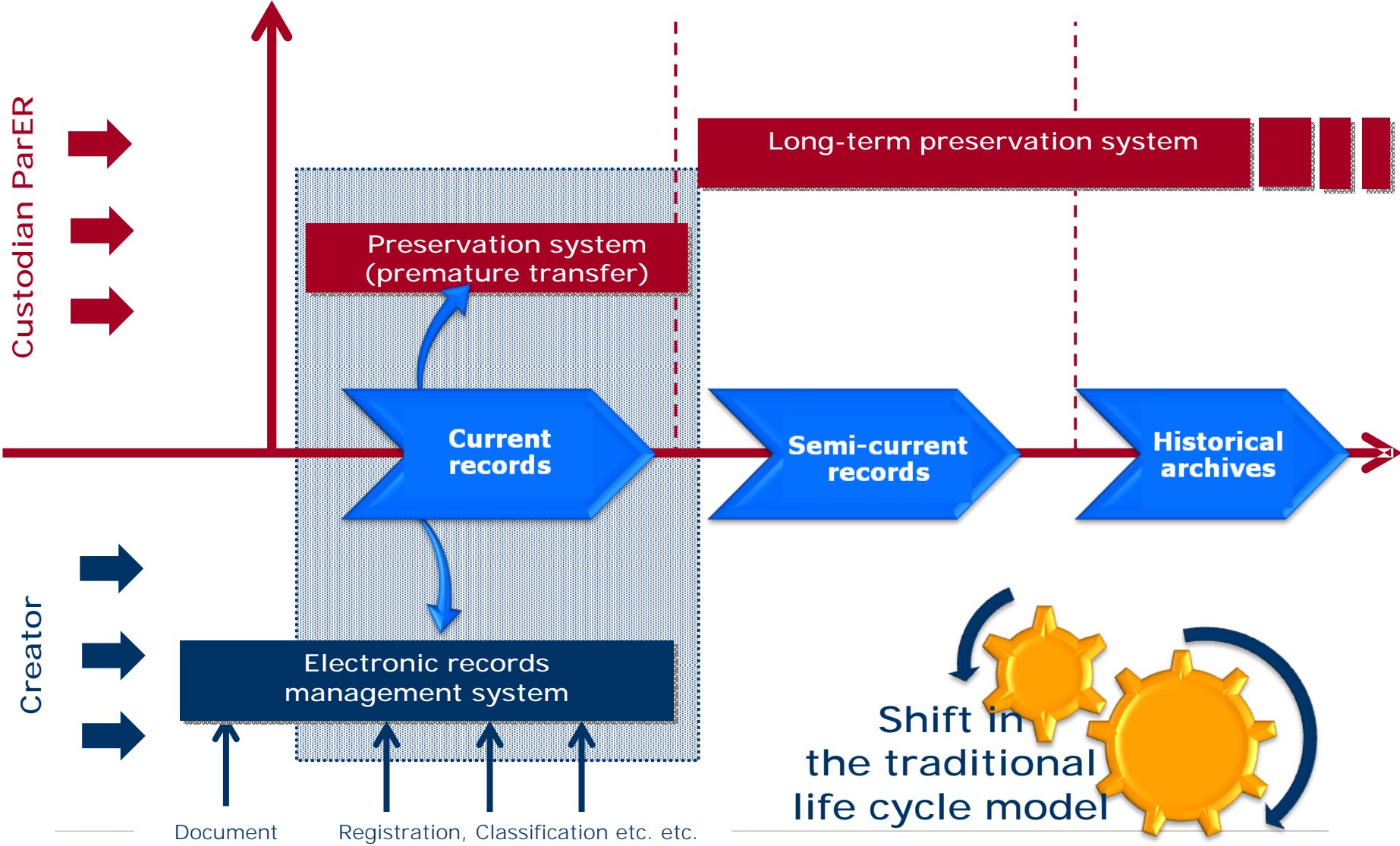

# The traces of a new archival paradigm (A): the relationship between ParER and the creator

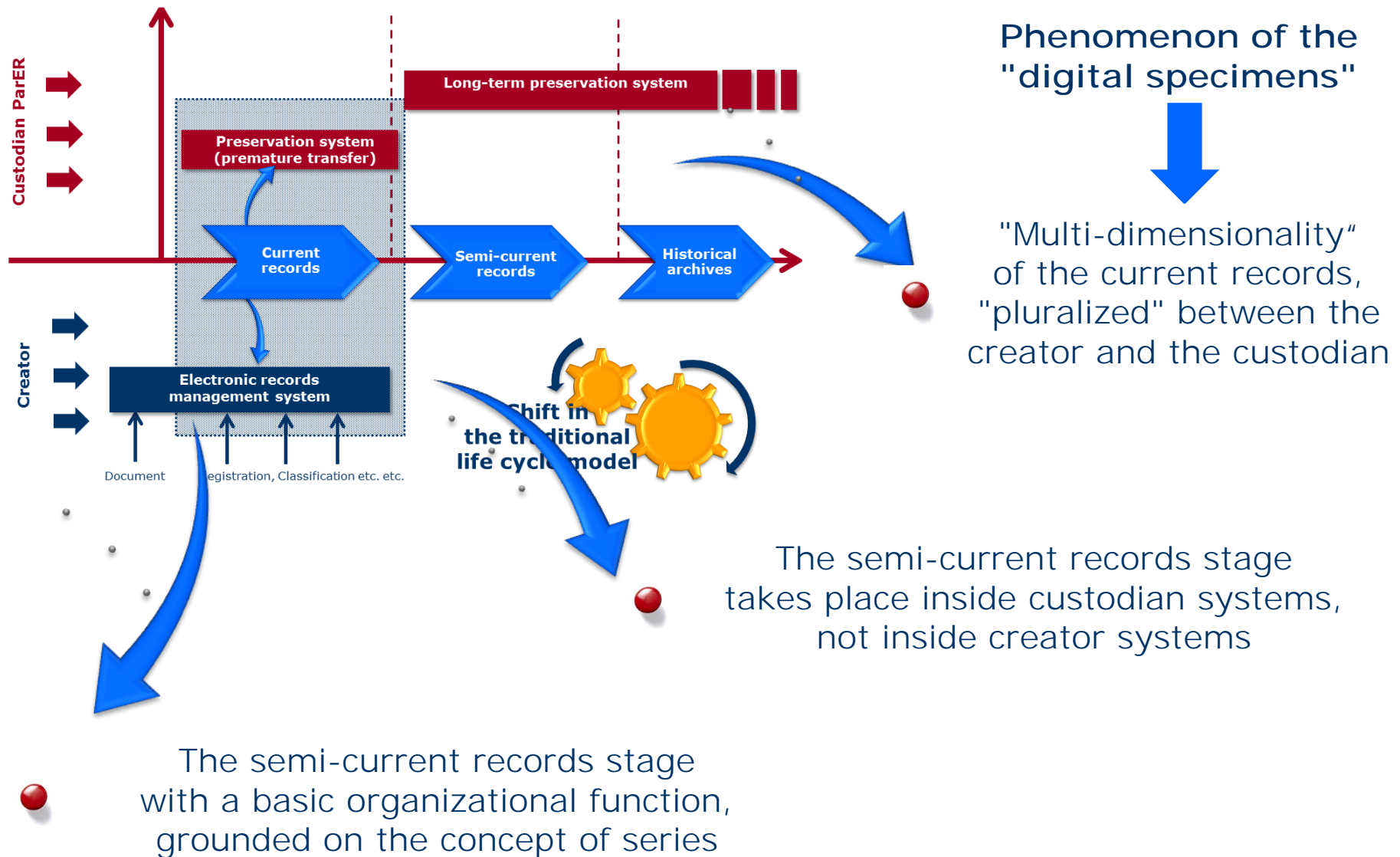

# The traces of a new archival paradigm (B): the nature of the historical archives

Historical archives



Traditional archival paradigm:

the permanent records that go beyond the "threshold archival" are recognized as intangible, stable, immutable reality from an **absolute point of view**



Shift of the traditional archival paradigm in ParER:

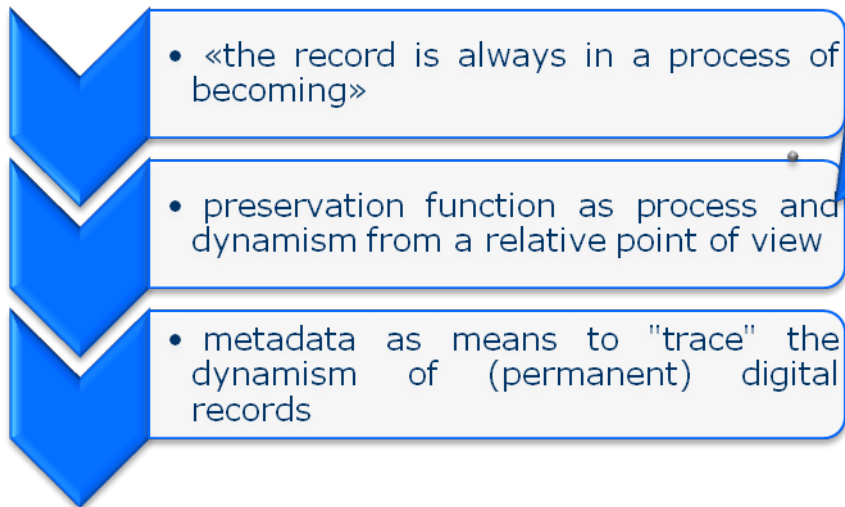

The permanent records that go beyond the "threshold archival" are in balance between dynamism and stability

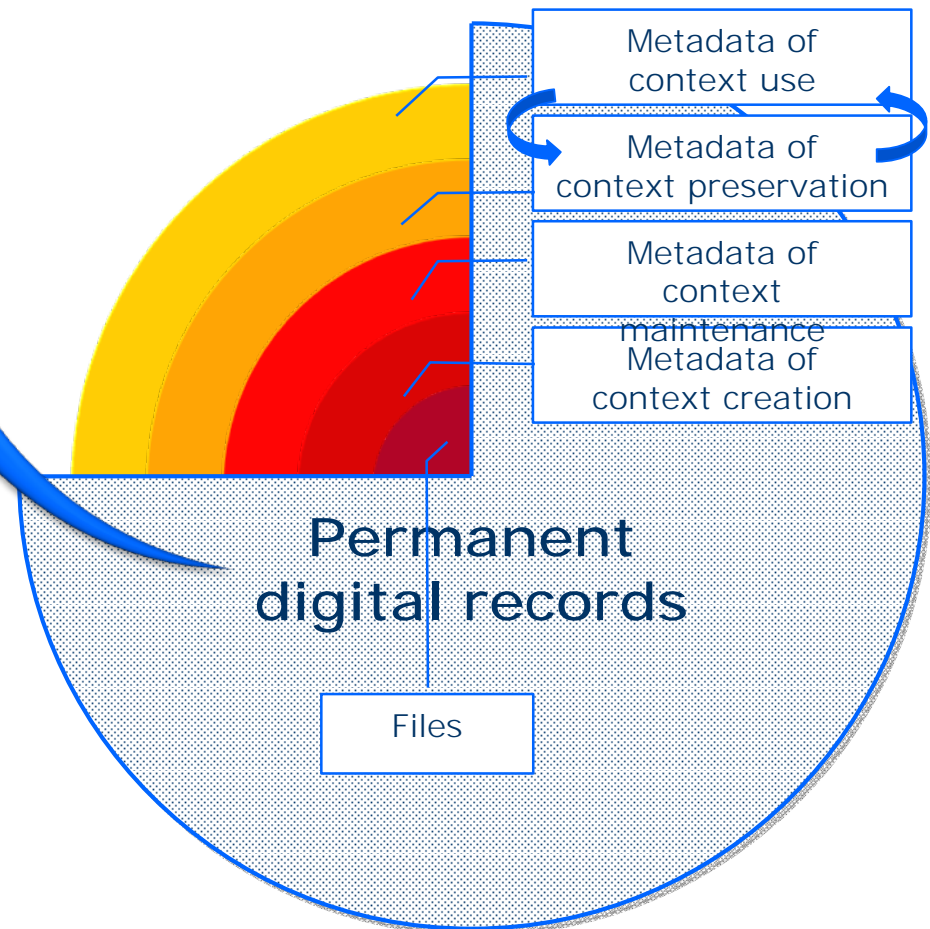

# The traces of a new archival paradigm (B): the nature of the historical archives

Archival  
description

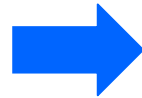

Traditional archival paradigm:

"Post-hoc description", carried out by archivists in charge of the historical archives preservation

Shift of the traditional archival paradigm in ParER:

- the hierarchical multilevel structure proceeds from the particular to the general
- the archival description can not be considered entirely "post hoc", because it starts with the current records stage
- AIPs belonging to the lower levels self-describe themselves through the metadata of contexts
- AIPs belonging to the higher levels represent the description carried out by the custodian archivists

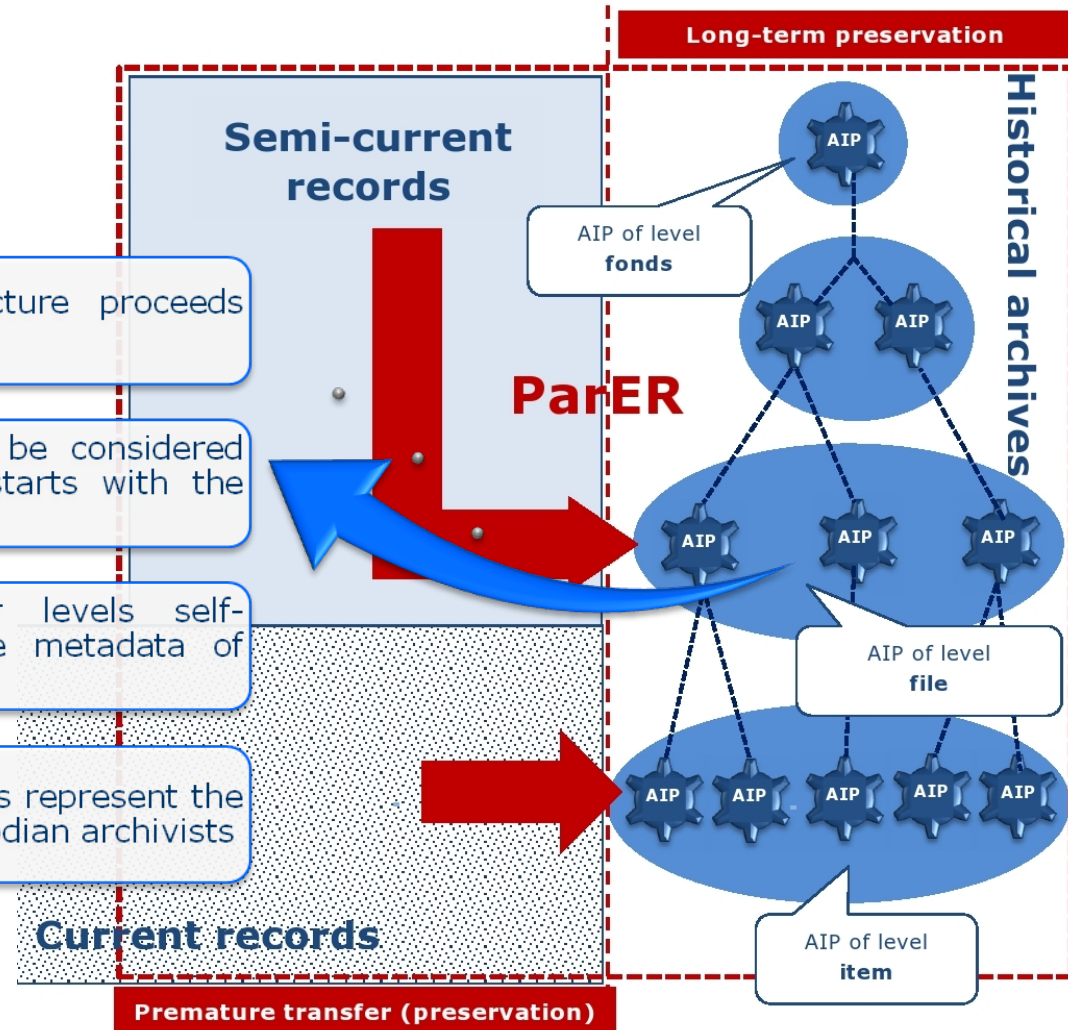

# The traces of a new archival paradigm (C): the relationship between users and archival description

